

SKF ROTOR BEARING

What are the lubrication requirements?

- Grease filled bearings are factory filled with Lubri-plate 1200-2.
- Flush & Re-grease bearings every 480-960 hours, depending on application.
- Grease quantity depends on bearings size. See WSM equipment manual for grease chart.

HAMMER WEAR

When should I change or rotate my three way hammers?

- Three way hammers have three usable surfaces for extended hammer life. Hammer life or expectancy is subjective and is different for each application. Here are some things to keep in mind to get best long term performance.

Once the leading edge of the hammer is worn down to about a 1" radius (a quarter can be used as a gauge) the hammer should be rotated.

- Hammers are rebuildable when wear is measured at $\frac{3}{4}$ " radius maximum (a nickel can be used as a gauge). WSM does sell gauges for inspecting hammer wear and rebuilding.
- Worn hammers will result in unacceptable product size, reduced grinder capacity and increased wear to all wear components (see below).

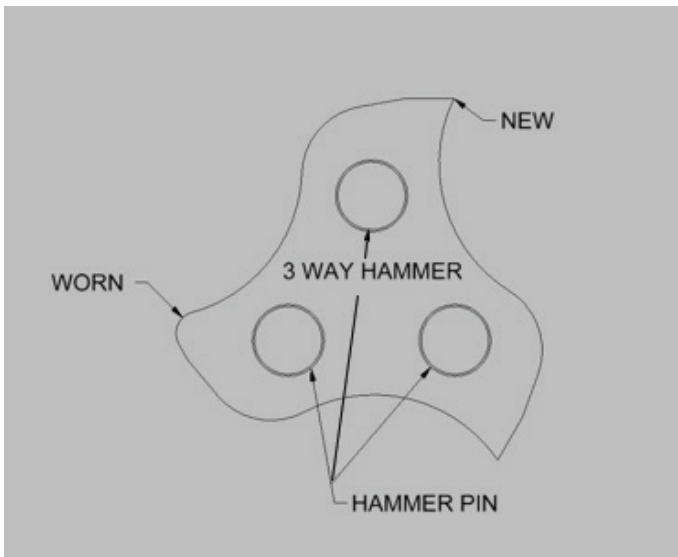

HAMMER WEAR - Cont.

When should I change or rotate my replaceable hammer tips?

WSM replaceable hammer tips are a square or rectangular tip that can be rotated to extend hammer life. Tips should be changed often enough to keep wear off of the hammer body. Once the hammer body has been worn down, you must replace the entire body. By keeping the hammer tips in good shape, you extend the life of the body. Once the leading edge of the hammer tip is worn off, it is time to rotate or change the tip (see below).

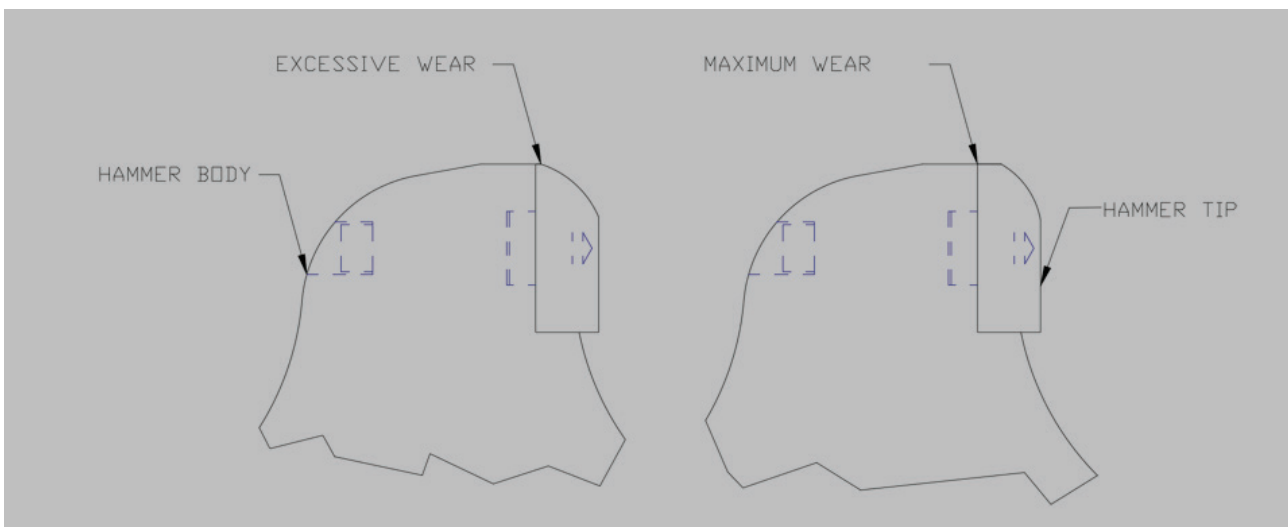

BREAKER BAR

When should I rotate or change my Breaker Bar?

The Breaker Bar is one of the primary wear parts of a grinder. Material is forced along it by the hammers, this causes it to wear like hammer tips. Breaker Bars can be rotated as long the wear is not excessive. The Breaker Bar should be inspected while inspecting the hammers & screens. When rotated properly, most Breaker Bars can be rotated 2-4 times before needing replacement.

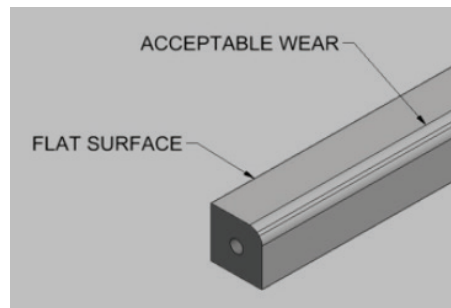
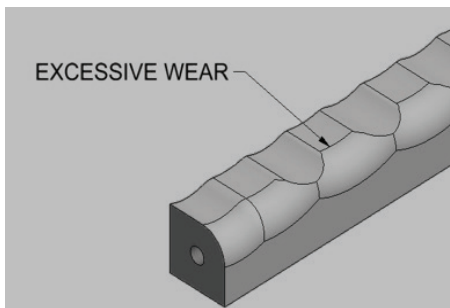

LINER WEAR

When do I replace or rotate my liners?

Liners in a WSM Grinder are designed to be replaceable to keep wear off the case components. Rotating worn liners will extend the life of the machine. Most WSM Breaker Plate liners are rotatable, but can only be rotated if the wear pattern is not excessive. The diagram below shows acceptable liner wear (time to rotate) and excessive liner wear (time to replace).

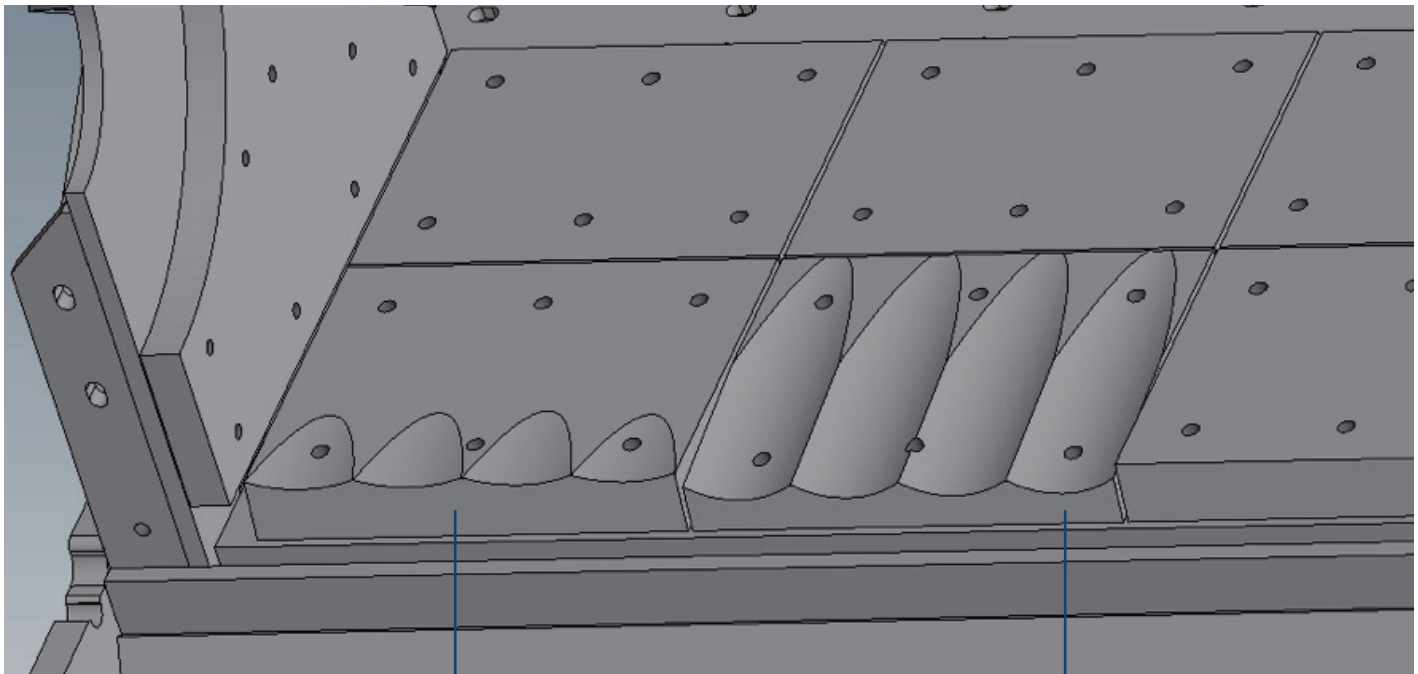

ACCEPTABLE WEAR
ROTATE LINER

EXCESSIVE WEAR
REPLACE LINER

Contact WSM's Parts and Service Team for more information and to answer any other questions you may have.

Dan: dang@westsalem.com
Darren: dbutcher@westsalem.com
Bill: billb@westsalem.com